



T 133 H
T 144 H PLUS



www.ausa.com

AUSA Center, S.L. ● Ctra. de Vic, Km 2.8 - P.O.B. 194. 08243 Manresa - BARCELONA (ESPAÑA) Tel.: +34 93 874 73 11 - E-mail: ausa@ausa.com

ISO 9001 ISO 14001



(Sede central AUSA-Manresa)

- AUSA Madrid** ● Pol. Ind. Coslada - C. Marconi 15-17. 28823 Coslada - MADRID (ESPAÑA) Tel.: +34 91 669 00 06 - E-mail: ausa.madrid@ausa.com
- AUSA France** ● Z. I. Saint Charles - Rue de Zürich, 66000 PERPIGNAN (FRANCE) Tel.: +33 (0) 4 68 54 38 97 - E-mail: ausa.france@ausa.com
- AUSA Deutschland** ● Heinrich - Welken Str. 5. 59069 HAMM (GERMANY) Tel.: +49 (0) 2385-9359362 - E-mail: ausa.deutschland@ausa.com
- BEIJING Rep. Office** ● Address Room 527. HengXiang Building, Tuanjieshu Nanli, Chaoyang District. - BEIJING 100026 (CHINA)
Tel.: 86-10-8597 1983 - Fax: 86-10-8597 1993 - E-mail: ausa.china@ausa.com
- AUSA UK** ● Tel.: 07970639988 - E-mail: ausa.uk@ausa.com
- AUSA Brasil** ● Tel.: +55 51 33622111 - E-mail: ausa.brasil@ausa.com
- AUSA México** ● Gustavo Baz, 47. 53489 Naucalpan de Juárez, Edo. de México (MÉXICO) Tel.: +55 2166-9066 - E-mail: ausa.mexico@ausa.com



FEM-AEM



T 133 H T 144 H PLUS



DIMENSIONS (mm)	T 133 H	T 144 H PLUS
A	1942	1942
B	270	270
C	1410	1410
D	2982	2982
E	485	580
F	1723	1723
G	383	383
H	123	230
I	1000	1000
J	3591	3710
K	310	310
L	2644	2900
M	748	1057
N	-	1690
O	-	3970
P	-	20°
R	-	40°

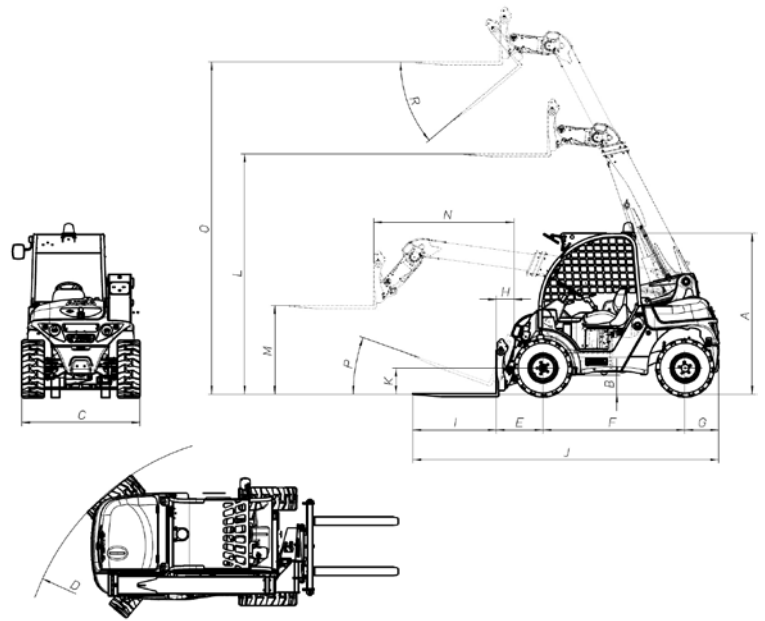

TECHNICAL SPECIFICATIONS

		T 133 H	T 144 H PLUS
Load capacity	Max. load	1.300 Kg @ 500 mm	1.350 Kg (1.250 Kg with Side shift @ 500 mm ^(*)) (1150 Kg with quick tach ^(**))
	Load at max. height	1.300 Kg @ 500 mm	1.350 Kg (1.250 Kg with Side shift @ 500 mm ^(*)) (1150 Kg with quick tach ^(**))
Lifting height	Maximum lifting height	2.644 mm @ 500 mm	3.990 mm @ 500 mm
	Lifting height at max. load	2.644 mm @ 500 mm	3.990 mm @ 500 mm
Reach	Max reach	458	2.180 mm
	Capacity at max reach	1.300 Kg	550 Kg (450 Kg with Side shift ^(*)) (350 Kg with quick tach ^(**))
Unload weight		2.200 Kg	2.400 Kg
Engine	Diesel	Kubota D-1105	Kubota V-1505
	Power acc./SAE J1995 (KW / HP)	16.8 / 22.8	22.7 / 30.8
	N° of cylinders	3	4
	Cooling system	Water	
Traction		Permanent 4x4 with hydraulic flow blocking	Permanent 4WD with automatic and hydraulic limited-slip wheels system exclusive AUSA
Transmission	Hydrostatic with variable flow pump automatic regulation (PATENTED) exclusive AUSA. Electrical inverter in joystick		
Engine starting system	Electric		
Speed		20 Km/h	17 Km/h
Gradient negotiable (with full load)		26%	26%
Hydraulic circuit	Working flow & pressure	19l @ 240 bar	
Tyres	Front	27x10 - 12	11.0 / 65x12
	Rear	27x10 - 12	11.0 / 65x12
External turning circle		2.982 mm	2.982 mm
Steering		Hydraulic / Rear wheels	
Tank capacity	Fuel	55l	
	Hydraulic fluid	32l	
Service brake		Hydrostatic retardation system	
Parking brake		Mechanically applied hydraulically released inside the hydrostatic motor	
STANDARD EQUIPMENT		-	Automatic audio-visual load moment indicator warning system
		-	Active safety equipment with boom locking by instability
			Homologated ROPS-FOPS cabin
			Joystick with integrated functions, "total control of movements"
			Adjustable ergonomic seat with safety belt
			Rear view mirror
			Audible reverse warning
			Rotating beacon
			Antivandalic system
			4th auxiliary hydraulic service with quick coupling
			Semi-closed cabin / Closed soundproof cabin with heater
			Windscreen front protective grid
			Load back rest
			Electronic anti-theft protection system
			Homologated lighting equipment / Working lights
	OPTIONAL EQUIPMENT		
			27x10-12 Wheels (SSL - Construction Pattern)
			FEM II forks carriage with or without integrated side-shift (TDL) ^(*)
			Bucket (300 l) / Multifunction 4 en 1 bucket
			Multiple attachments available proven and tested from factory
		-	Hydraulic quick-tach carriage EURO 8 type (1150 Kg load capacity) ^(**)
		-	Hydraulic quick-tach carriage Universal-SSL type (1150 Kg load capacity) ^(**)
		-	High & continuous flow (45 l/min @ 200 bar)

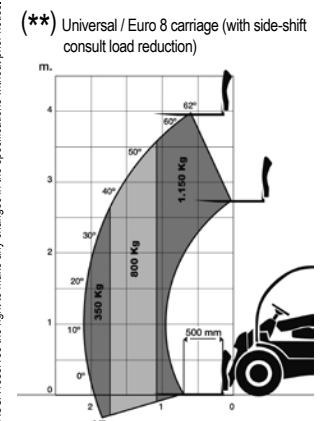
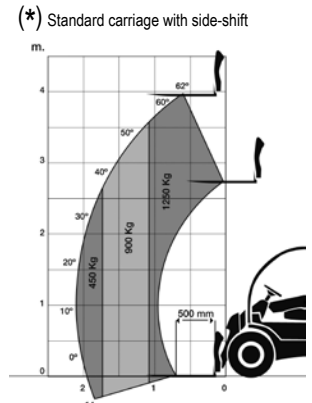
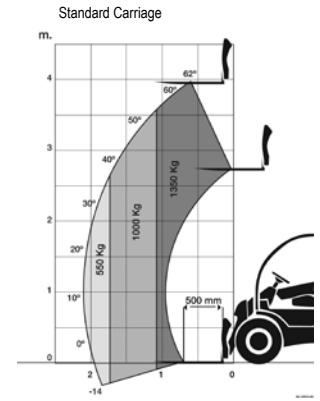

AUSA reserves the right to make any changes in the specifications without prior notice.